

### General Description

The ZM280N06S combines advanced trench MOSFET technology with a low resistance package to provide extremely low  $R_{DS(ON)}$ . This device is ideal for load switch and battery protection applications.

### Features

- Advance high cell density Trench technology
- Low  $R_{DS(ON)}$  to minimize conductive loss
- Low Gate Charge for fast switching
- Low Thermal resistance

### Application

- MB/VGA Vcore
- SMPS 2<sup>nd</sup> Synchronous Rectifier
- POL application
- BLDC Motor driver

### Product Summary

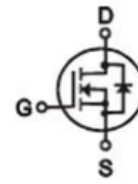

$$V_{DS} = 60V$$

$$R_{DS(ON)} = 28m\Omega$$

$$I_D = 7A$$

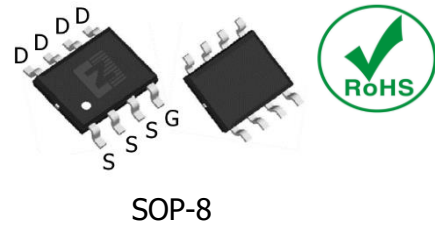

### Ordering Information:

Part NO.	ZM280N06S
Marking	ZM280N06
Packing Information	REEL TAPE
Basic ordering unit (pcs)	4000

### Absolute Maximum Ratings ( $T_C = 25^\circ C$ )

Parameter	Symbol	Rating	Unit
Drain-Source Voltage	$V_{DS}$	60	V
Gate-Source Voltage	$V_{GS}$	$\pm 20$	V
Continuous Drain Current	$I_{D@TC=25^\circ C}$	7	A
	$I_{D@TC=75^\circ C}$	5.3	A
	$I_{D@TC=100^\circ C}$	4.4	A
Pulsed Drain Current <sup>①</sup>	$I_{DM}$	15	A
Total Power Dissipation( $TC=25^\circ C$ )	$P_D@TC=25^\circ C$	4.0	W
Total Power Dissipation( $TA=25^\circ C$ )	$P_D@TA=25^\circ C$	0.75	W
Operating Junction Temperature	$T_J$	-55 to 150	$^\circ C$
Storage Temperature	$T_{STG}$	-55 to 150	$^\circ C$
Single Pulse Avalanche Energy	$E_{AS}$	55	mJ

**•Thermal resistance**

Parameter	Symbol	Min.	Typ.	Max.	Unit
Thermal resistance, junction - case	$R_{thJC}$	-	-	32	$^{\circ}C/W$
Thermal resistance, junction - ambient	$R_{thJA}$	-	-	170	$^{\circ}C/W$
Soldering temperature, wave soldering for 10s	$T_{sold}$	-	-	265	$^{\circ}C$

**•Electronic Characteristics**

Parameter	Symbol	Condition	Min.	Typ	Max.	Unit
Drain-Source Breakdown Voltage	$BV_{DSS}$	$V_{GS}=0V, I_D=250\mu A$	60			V
Gate Threshold Voltage	$V_{GS(TH)}$	$V_{GS}=V_{DS}, I_D=250\mu A$	1.2		2.5	V
Drain-Source Leakage Current	$I_{DSS}$	$V_{DS}=60V, V_{GS}=0V$			1.0	$\mu A$
Gate- Source Leakage Current	$I_{GSS}$	$V_{GS}=\pm 20V, V_{DS}=0V$			$\pm 100$	nA
Static Drain-source On Resistance	$R_{DS(ON)}$	$V_{GS}=10V, I_D=6A$		28	36	m $\Omega$
		$V_{GS}=4.5V, I_D=4A$		33	43	m $\Omega$
Forward Transconductance	$g_{FS}$	$V_{DS}=25V, I_D=5A$		14		s
Source-drain voltage	$V_{SD}$	$I_S=6A$			1.28	V

**•Electronic Characteristics**

Parameter	Symbol	Condition	Min.	Typ	Max.	Unit
Input capacitance	$C_{iss}$	$V_{GS}=0V, V_{DS}=25V$ $f = 1MHz$	-	1430	-	pF
Output capacitance	$C_{oss}$		-	160	-	
Reverse transfer capacitance	$C_{rss}$		-	115	-	

**•Gate Charge characteristics( $T_a = 25^{\circ}C$ )**

Parameter	Symbol	Condition	Min.	Typ	Max.	Unit
Total gate charge	$Q_g$	$V_{DD} = 25V$ $I_D = 4A$ $V_{GS} = 10V$	-	19	-	nC
Gate - Source charge	$Q_{gs}$		-	9	-	
Gate - Drain charge	$Q_{gd}$		-	11	-	

Note: ① Pulse Test : Pulse width  $\leq 300\mu s$ , Duty cycle  $\leq 2\%$  ;

Fig.1 Power Dissipation

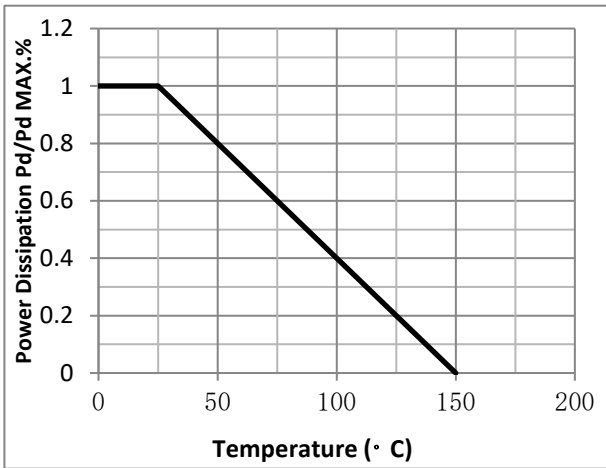

Fig.2 Typical output Characteristics

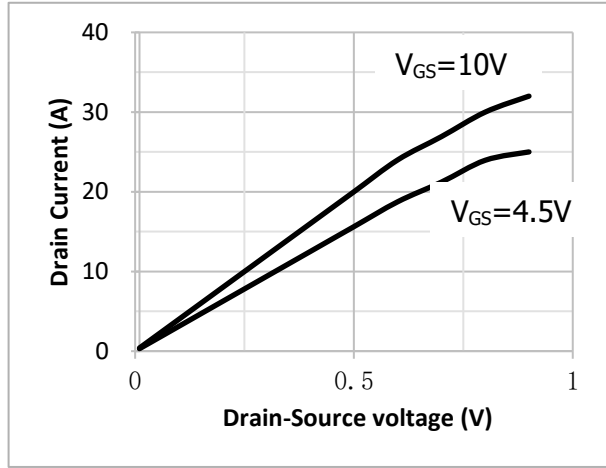

Fig.3 Threshold Voltage V.S Junction Temperature

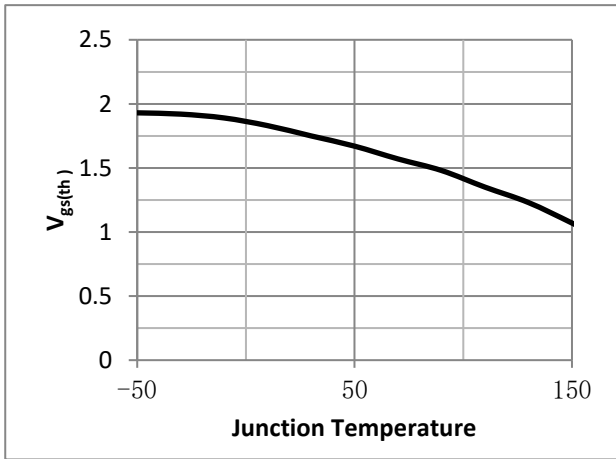

Fig.4 Resistance V.S Drain Current

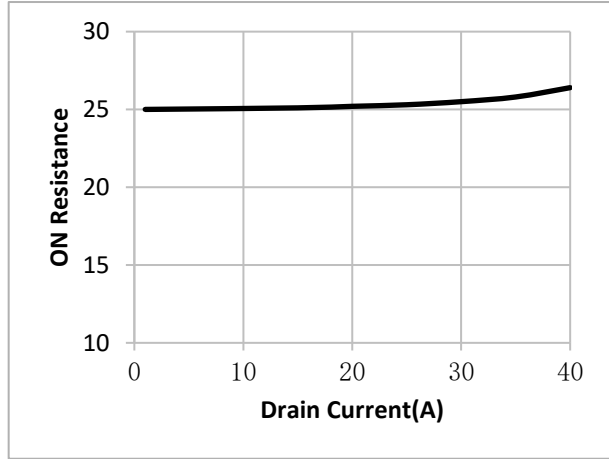

Fig.5 On-Resistance VS Gate Source Voltage

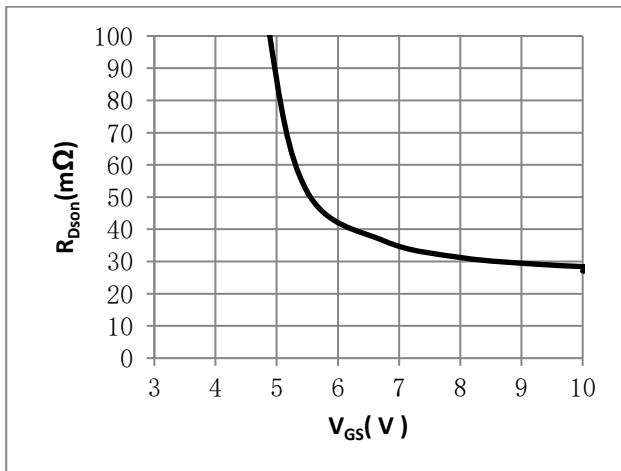

Fig.6 On-Resistance V.S Junction Temperature

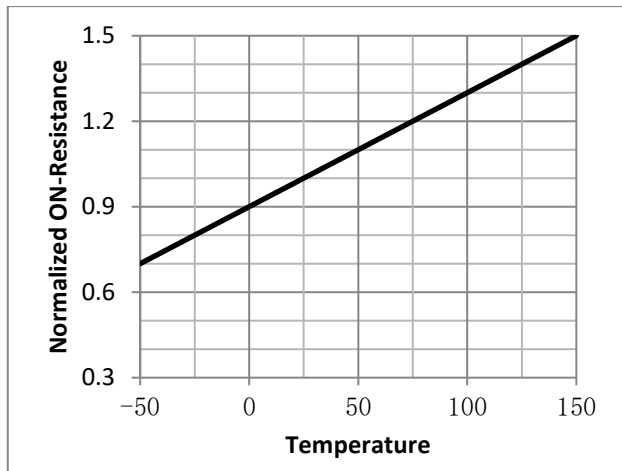

Fig.7 Switching Time Measurement Circuit

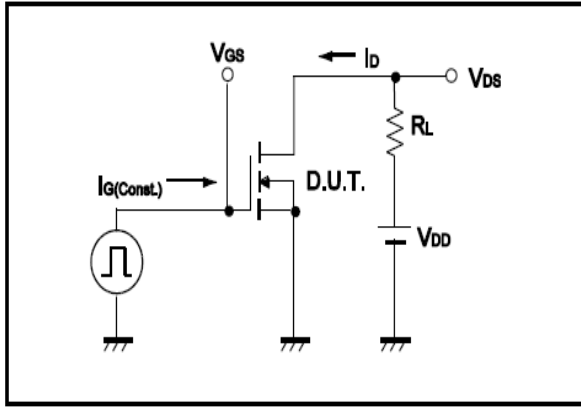

Fig.8 Gate Charge Waveform

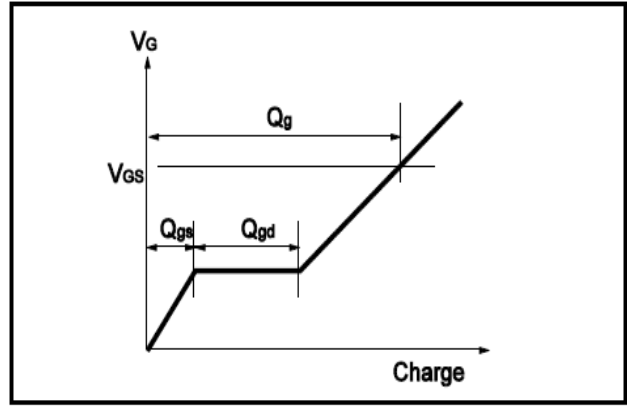

Fig.9 Switching Time Measurement Circuit

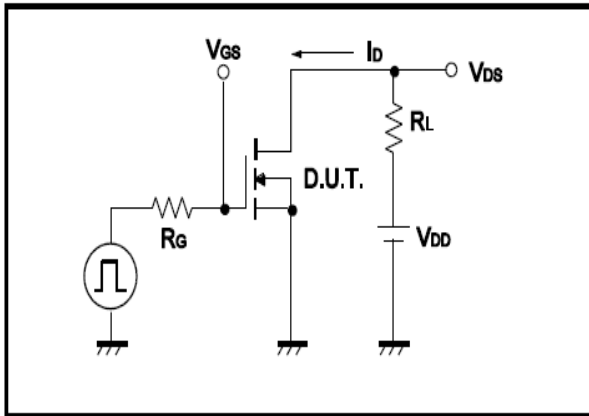

Fig.10 Gate Charge Waveform

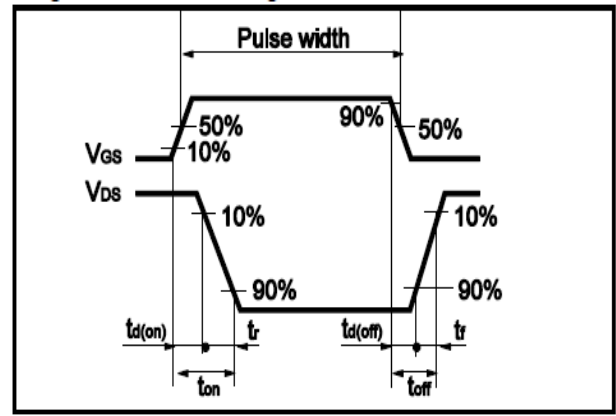

Fig.11 Avalanche Measurement Circuit

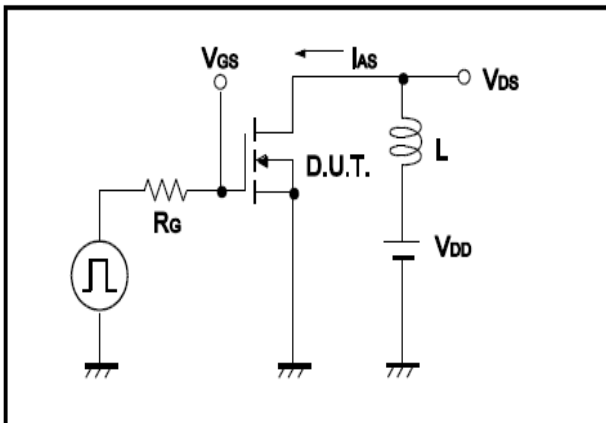
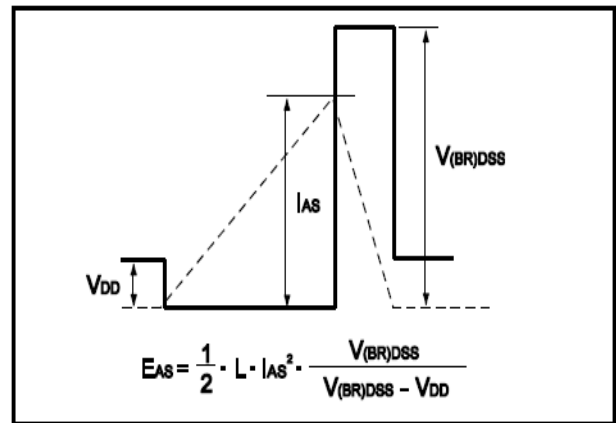

Fig.12 Avalanche Waveform



•Dimensions(SOP8)

Unit: mm

SYMBOL	min	TYP	max	SYMBOL	min		max
A	4.80		5.00	C	1.30		1.50
A1	0.37		0.47	C1	0.55		0.75
A2		1.27		C2	0.55		0.65
A3		0.41		C3	0.05		0.20
B	5.80		6.20	C4	0.19	0.20	0.23
B1	3.80		4.00	D		1.05	
B2		5.00		D1	0.40		0.62

